

**PUNTATRICI A DISCESA RETTILINEA MEDIA FREQUENZA**  
**MEDIUM FREQUENCY LINEAR ACTION SPOT WELDERS**  
**MITTELFREQUENZ PUNKTSCHWEISSMASCHINEN IN LINEAR**



- Saldatrice a punti a discesa rettilinea, alimentazione trifase;
- Trasformatore, braccio, portaelettrodo ed elettrodo raffreddati ad acqua;
- Cilindro doppia corsa regolabile (a richiesta);
- Three -phase linear action spot welder;
- Water-cooled transformer, lower arm, electrode holder and electrode;
- Adjustable double stroke cylinder (on request);
- Dreiphasige Säulenpunktschweißmaschinen in Linearausführung;
- Transformator, Arme, elektrodenträger und Elektroden wassergekühlt;
- Regelbare Doppelhubzylinder (auf Anfrage).

## PF **INVERTER** series



### PX1700PRO MFDC

Controllo di saldatura display grafico per il comando del generatore inverter media frequenza HP400  
 Welding control with graphic display for the control of medium frequency inverter generator HP400  
 Schweißsteuerung grafische Darstellung für die Steuerung des Inverters Medium Frequenzgeneratoren HP400

CARATTERISTICHE TECNICHE	TECHNICAL DATA	TECHNISCHE DATEN		PF136 INVERTER	PF181 INVERTER
Potenza nominale al 50%	Rated power @ 50% duty cycle	Nennleistung bei 50%	kVA	35	88
Potenza nominale al 20%	Rated power @ 20% duty cycle	Nennleistung bei 20%	kVA	55	140
Corrente secondaria di corto circuito	Short circuit sec. current	Sekundärer Kurzschluss-Strom	kA	23,5	30
Forza agli elettrodi (6 bar)	Electrodes force (6 bar)	Elektrondekraft (6 bar)	daN	300	525
Tensione di alimentazione trifase	Nominal power supply three-phase	Anschlußspannung 3-phasig	V	400	400
Fusibili ritardati	Delayed fuses	Absicherung (träge)	A	32	63
Consumo aria	Air consumption	Luftbedarf	l/weld	4.0	8.0
Consumo acqua	Water consumption	Wasserbedarf	l/min	9	9
Aria compressa	Compressed air pressure	Luftdruck	bar	6	6
Profondità utile	Useful depth	Ausladung	mm	430	430
Corsa elettrodi	Electrodes stroke	Elektroden Hub	mm	60	60
Peso	Weight	Gewicht	Kg	334	360

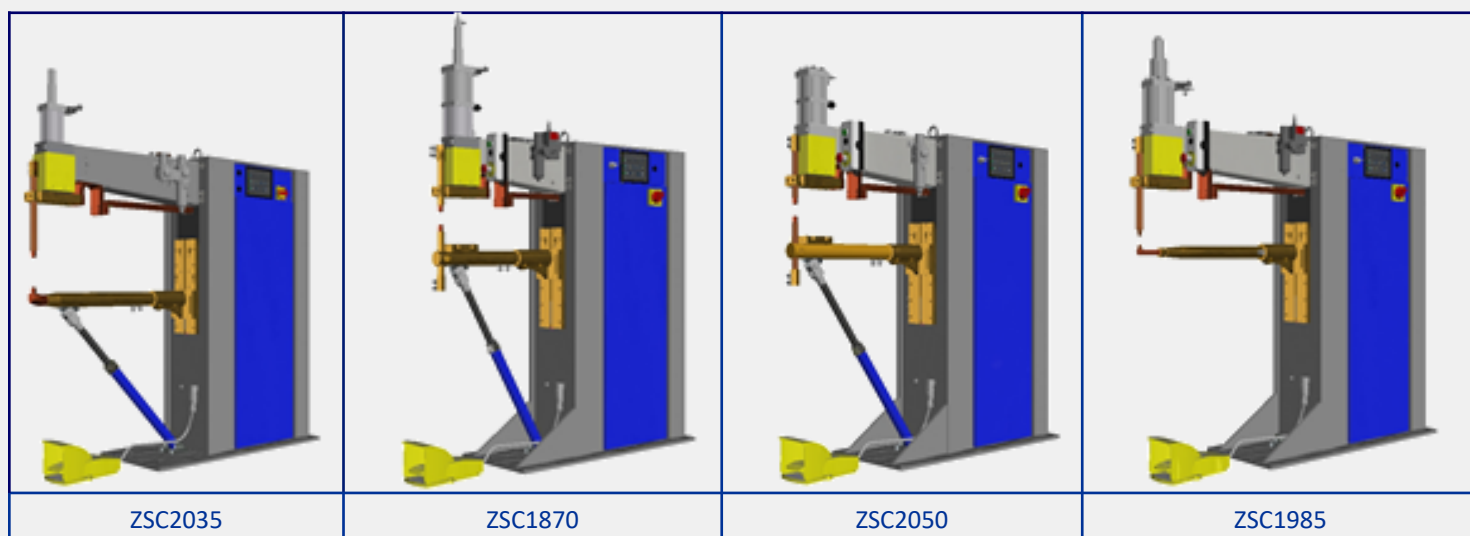

P.E.I.-POINT si riserva il diritto di modificare le specifiche senza alcun preavviso  
 P.E.I.-POINT reserve the right to modify specifications without prior notice  
 P.E.I.-POINT behält sich das Recht die spezifischen ohne Benachrichtigung zu ändern vor